

Product Details

HL Slot Channel

Technical Data

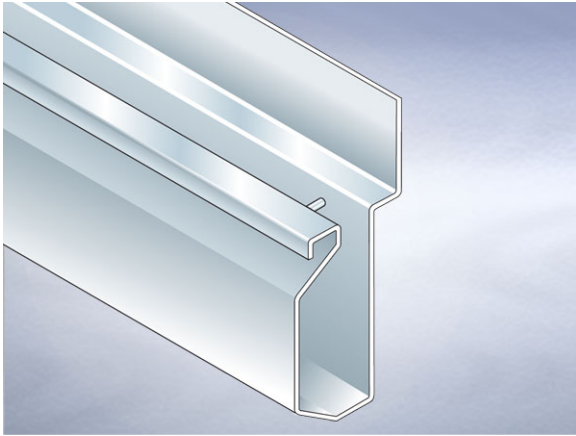

Dimensions:

-

Materials - Stainless steel

General Description:

Stainless Steel Supaslot Slot Channel (Designed for use against a wall). Supaslot channels are suited for large areas with only low volumes of waste water such as in abattoirs, butcheries, dairies, breweries etc. Neat and unobtrusive, the channels are a popular choice as a barrier between designated wet and dry zones.

Materials:

Stainless Steel - Austenitic Grade 304 and 316: Used for bodies, gratings, funnels, access covers, filter buckets and fixings. A corrosion-resistant metal containing significant amounts of nickel and chromium; AISI grade 304 stainless steel is used as standard, which is suitable for general use in and around buildings including most coastal locations. In applications such as swimming pools or having an aggressive atmosphere, grade 316 is recommended and is available on request. An even higher grade may be required for applications in highly corrosive environments including where exposure to seawater may be anticipated. Clean with soap and warm water rinse and wipe dry. Gratings may also be cleaned in certain dishwashers. Under no circumstances treat with metal scouring pads, metal scrapers or wire wool as these will contaminate surfaces leaving rust spots. Take care to cover stainless steel items when site work is going on, to avoid contamination with rust-inducing particles such as when mild steel or cast iron items are being cut.

All dimensions are in millimetres unless stated. In line with general practice all dimensions shown are nominal.

Wade International Ltd.

Third Avenue, Halstead, Essex, CO9 2SX.

Telephone: +44 (0)1787 475151

Fax: +44 (0)1787 475579

e-mail: tech@wadeint.co.uk

website: www.wadedrainage.co.uk

Typical Installation for HL:

Note: This illustration may show a similar Wade Product - it is intended to show the general installation type only.

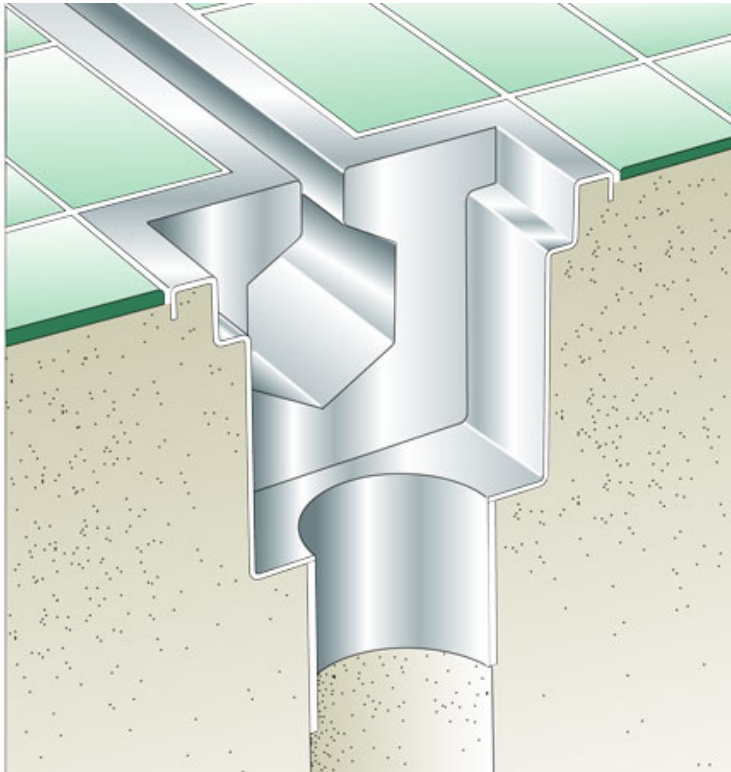

Dimensioned Section for HL:

