



Quality Drainage Products

Product Details

D1107LD Non-Trapped Body for use with Bituminous Membrane **Technical Data**

Dimensions:

305 dia. body

248 - Height below Body Flange

Connection - 2" BS416 / Harmer SML

Free Area - 19cm²

Materials - Cast iron, lacquered

Weight - 4.2 kg

General Description:

Cast Iron D10 - D12 series Non-Trapped Body for use with Bituminous Membrane (Version for use with Wade stainless steel drainage channels.), with 60 dia. vertical outlet. D1107 gullies have a wide flange to enable effective clamping of a bituminous damp-proof membrane. Membrane clamping collar is machined to accept a standard 114 diameter channel outlet spigot.

Options:

To specify an option, add option letter(s) as a suffix to the Spec. Code
W - weepholes (provide supplementary drainage at membrane level)

Materials:

Cast Iron - BS EN 1561: Used for bodies, membrane clamping collars, spigot adaptors and accessories such as extensions. A widely used metal in the drainage industry, its resistance to corrosion permits extended use under extreme conditions. Castings are coated with a high grade lacquer paint to provide internal and external surface coverage. Paint will gradually wear off and is replaceable; oxidation (surface rusting) is a natural process which does not weaken the material. A zinc anti-corrosion coating is applied to certain castings by sherardizing.

All dimensions are in millimetres unless stated. In line with general practice all dimensions shown are nominal.

Wade International

Third Avenue, Halstead, Essex, CO9 2SX.

Telephone: +44 (0)1787 475151

Fax: +44 (0)1787 475579

e-mail: wadetech@alumascwms.co.uk

website: <https://www.alumascwms.co.uk/brands/wade/>

Typical Installation for D1107LD:

Note: This illustration may show a similar Wade Product - it is intended to show the general installation type only.

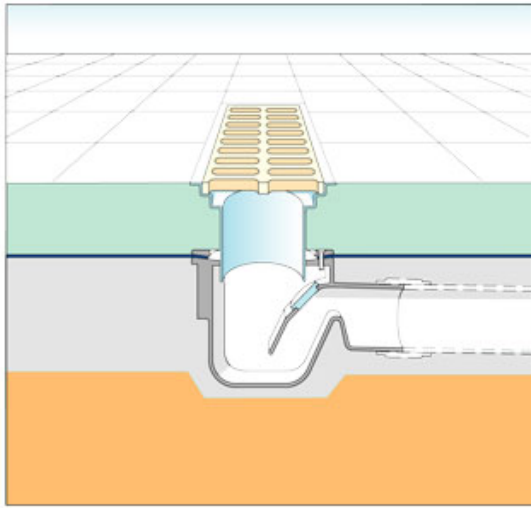

With 'P' trapped body.

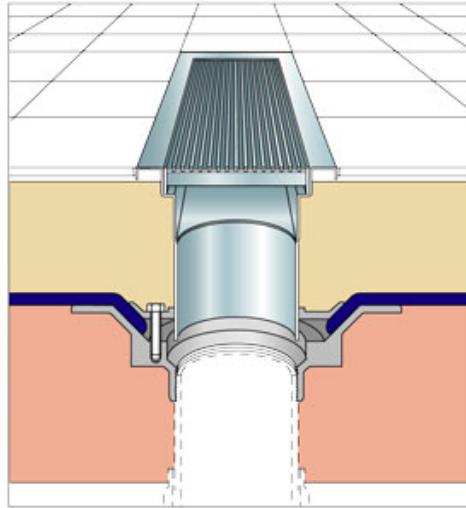

With non-trapped body.

Dimensioned Section for D1107LD: