

**Product Details**

**WC814 Outlet with Circular Dome**

**Technical Data**

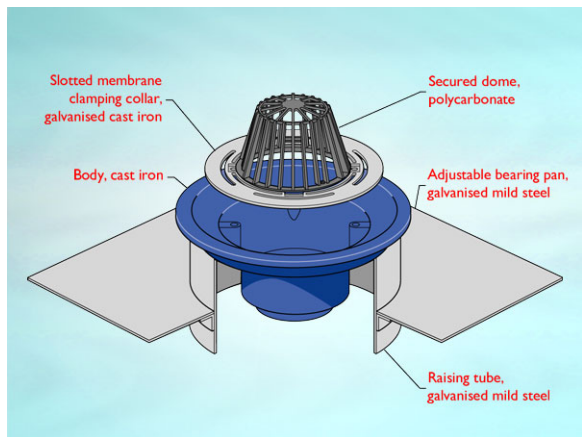

**Dimensions:**

310 dia. at finish level  
 405 dia. body  
 600 square overall size  
 149 - Height below Body Flange  
 20 to 135 - min/max height between roof deck and membrane level

**Connection** - female 4" BSP threaded connection (100mm)

**Free Area** - body= 78cm<sup>2</sup>, grating= 510cm<sup>2</sup>

**Materials** - Dome - polycarbonate; Body - cast iron; Membrane Clamp - cast iron, lacquered

**Load Rating Class** - H1.5

**Weight** - 20.7 kg

**General Description:**

310 Dia. Cast Iron 3100 series (Deep Sump) Warm Roof Outlet with Circular Dome, with 4" BSP dia. vertical outlet.

**Options:**

To specify an option, add option letter(s) as a suffix to the Spec. Code

K - bonded insulation jacket

SS - stainless steel dome

Z - rigid PVC flange for use with PVC single ply membranes

**Materials:**

**Cast Iron - BS EN 1561:** Used for bodies, membrane clamping collars, spigot adaptors and accessories such as extensions. A widely used metal in the drainage industry, its resistance to corrosion permits extended use under extreme conditions. Castings are coated with a high grade lacquer paint to provide internal and external surface coverage. Paint will gradually wear off and is replaceable; oxidation (surface rusting) is a natural process which does not weaken the material. A zinc anti-corrosion coating is applied to certain castings by sherardizing.

**Polycarbonate:** Used for domes. A polycarbonate/ABS blend which offers durability, high impact strength and long-term resistance to ultraviolet light.

All dimensions are in millimetres unless stated. In line with general practice all dimensions shown are nominal.

Wade International

Third Avenue, Halstead, Essex, CO9 2SX.

Telephone: +44 (0)1787 475151

Fax: +44 (0)1787 475579

e-mail: wadetech@alumascwms.co.uk

website: <https://www.alumascwms.co.uk/brands/wade/>

**Typical Installation for WC814:**

Note: This illustration may show a similar Wade Product - it is intended to show the general installation type only.

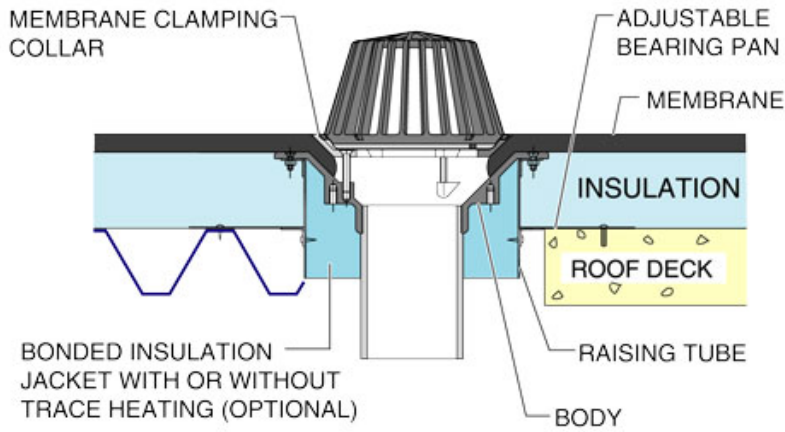

**Dimensioned Section for WC814:**

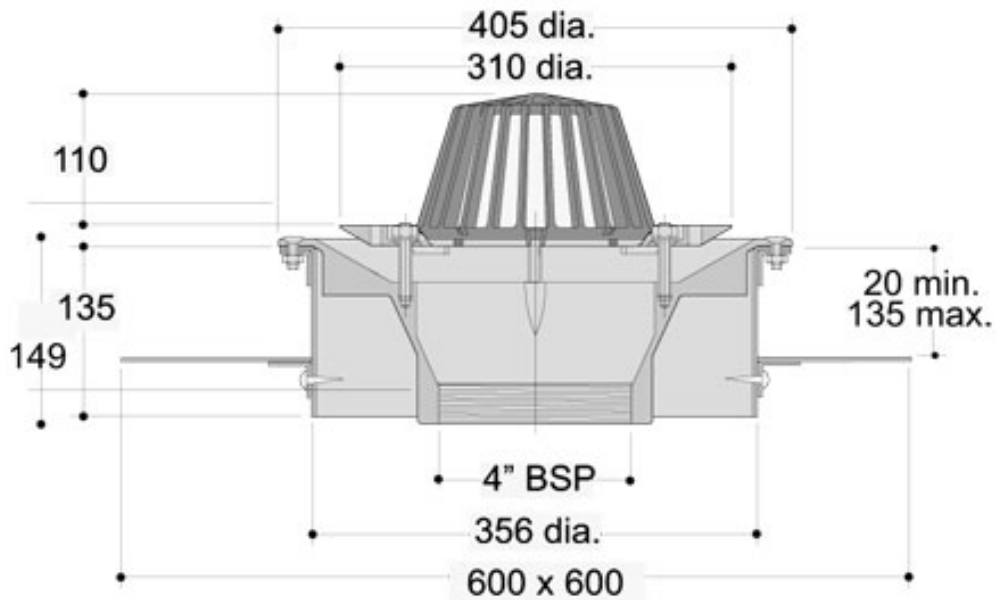

**Flow Performance Figures for WC814:**

<b>Head of water at outlet</b>	<b>15mm</b>	<b>20mm</b>	<b>25mm</b>	<b>30mm</b>	<b>35mm</b>	<b>40mm</b>	<b>50mm</b>
<b>Flow Rate (l/s):</b>	2.85	4.4	5.74	6.95	7.73	8.1	8.1
<b>Roof area drained (m<sup>2</sup>) at 0.021 l/s per m<sup>2</sup> rainfall rate:</b>	136	210	273	331	368	386	386

**Note:** Flow rates of Wade roof outlets have been established by full-scale tests. The values shown in the table are 75% of such tests. The design of the layout of roof outlets should be in accordance with the recommendations given in BS EN 12056:3.