

Product Details

U1704 Removable bell trap

Technical Data

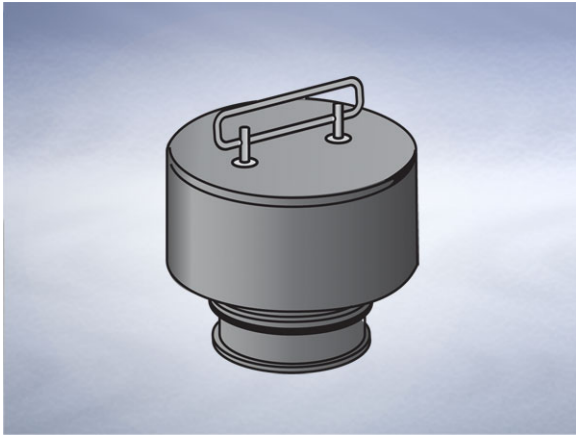

Dimensions:

160 dia. overall size

155 - Overall Height

Materials - HDPE, Neoprene

Weight - 0.5 kg

General Description:

General Purpose Removable bell trap (50mm trap seal depth). To fit inside a 4" channel outlet. Note channel will be designed with a sump at the outlet to accommodate the trap.

All dimensions are in millimetres unless stated. In line with general practice all dimensions shown are nominal.

Wade International

Third Avenue, Halstead, Essex, CO9 2SX.

Telephone: +44 (0)1787 475151

Fax: +44 (0)1787 475579

e-mail: wadetech@alumascwms.co.uk

website: <https://www.alumascwms.co.uk/brands/wade/>

Typical Installation for U1704:

Note: This illustration may show a similar Wade Product - it is intended to show the general installation type only.

