

Product Details

K2193CI Grating

Technical Data



Dimensions:

155 dia. at finish level

54 - Overall Height

Connection - 110mm Plastic, 100mm DIN19522 / 4" BS416 / Harmer SML

Free Area - 58cm²

Materials - Cast iron, sherardized

Load Rating Class - K3

Weight - 1.7 kg

General Description:

155 Dia. Cast Iron Direct Connection Grating, for use with unfinished (eg. bare concrete) or paved areas (Standard circular grating), with 110.2 dia. vertical outlet. Robust and durable items, suited for pedestrian areas with high volumes of traffic, and also for restoration or refurbishment projects where there is a requirement to match period architecture.

Options:

To specify an option, add option letter(s) as a suffix to the Spec. Code

H - fitted with Pin Torx screws for security applications

Materials:

Cast Iron - BS EN 1561: Used for bodies, membrane clamping collars, spigot adaptors and accessories such as extensions. A widely used metal in the drainage industry, its resistance to corrosion permits extended use under extreme conditions. Castings are coated with a high grade lacquer paint to provide internal and external surface coverage. Paint will gradually wear off and is replaceable; oxidation (surface rusting) is a natural process which does not weaken the material. A zinc anti-corrosion coating is applied to certain castings by sherardizing.

All dimensions are in millimetres unless stated. In line with general practice all dimensions shown are nominal.

Wade International

Third Avenue, Halstead, Essex, CO9 2SX.

Telephone: +44 (0)1787 475151

Fax: +44 (0)1787 475579

e-mail: wadetech@alumascwms.co.uk

website: <https://www.alumascwms.co.uk/brands/wade/>

Typical Installation for K2193CI:

Note: This illustration may show a similar Wade Product - it is intended to show the general installation type only.

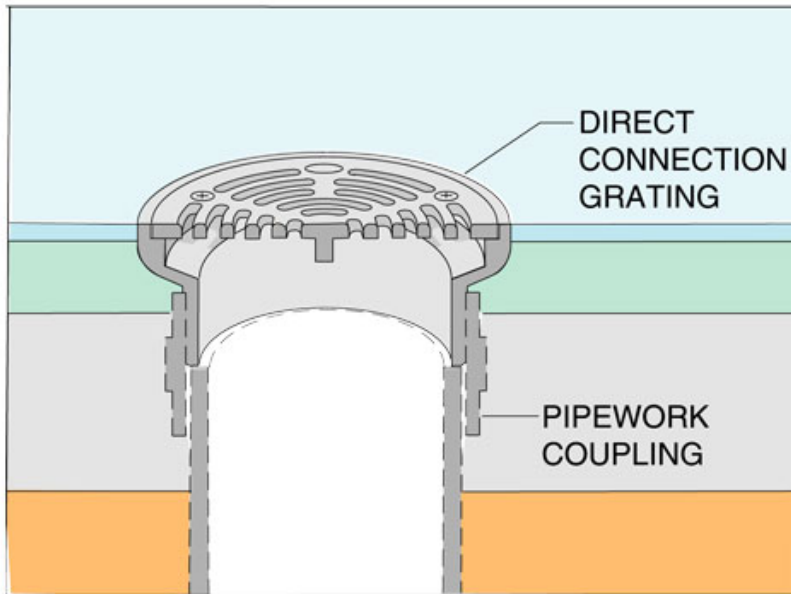

Dimensioned Section for K2193CI:

