

Product Details

GV5007 'P' Trapped Shower Gully Assembly

Technical Data



Dimensions:

160 dia. at finish level

220 dia. body

6 - grating aperture width

105 - Height below Body Flange

105 - depth body flange to outlet invert

Connection - 50mm solvent weld plastic socket (2")

Free Area - 14cm²

Materials - Grating, clamping collar - stainless steel; Body, dip tube, bucket - plastic (ABS)

Load Rating Class - K3

Weight - 1.2 kg

General Description:

160 Dia. Stainless Steel 'P' Trapped Shower Gully Assembly, for use with flexible sheet floor covering (eg. vinyl) (2" socket outlet.), with 2" Socket BS 5255 dia. horizontal outlet with 6mm grating aperture width . GV5007 is a compact, lightweight, 'trapped gully with peripheral slot drainage for use in shower areas decked with flexible sheet floor covering such as vinyl, up to 3.5mm thickness.

Options:

To specify an option, add option letter(s) as a suffix to the Spec. Code
P - has a polished finish

Materials:

ABS: Used for bodies, dip tubes, extensions and spigot adaptors. A cost effective, fire resistant material.

Stainless Steel - Austenitic Grade 304 (Grade 316 optional on most products): Used for bodies, gratings, funnels, access covers, filter buckets and fixings. A corrosion-resistant metal containing significant amounts of nickel and chromium; AISI grade 304 stainless steel is used as standard, which is suitable for general use in and around buildings including most coastal locations. In applications such as swimming pools or having an aggressive atmosphere, grade 316 is recommended and is available optionally (if available, code 'M' will be listed under 'Options'). An even higher grade may be required for applications in highly corrosive environments including where exposure to seawater may be anticipated. Clean with soap and warm water rinse and wipe dry. Gratings may also be cleaned in certain dishwashers. Under no circumstances treat with metal scouring pads, metal scrapers or wire wool as these will contaminate surfaces leaving rust spots. Take care to cover stainless steel items when site work is going on, to avoid contamination with rust-inducing particles such as when mild steel or cast iron items are being cut.

All dimensions are in millimetres unless stated. In line with general practice all dimensions shown are nominal.

Wade International

Third Avenue, Halstead, Essex, CO9 2SX.

Telephone: +44 (0)1787 475151

Fax: +44 (0)1787 475579

e-mail: wadetech@alumascwms.co.uk

website: <https://www.alumascwms.co.uk/brands/wade/>

Typical Installation for GV5007:

Note: This illustration may show a similar Wade Product - it is intended to show the general installation type only.

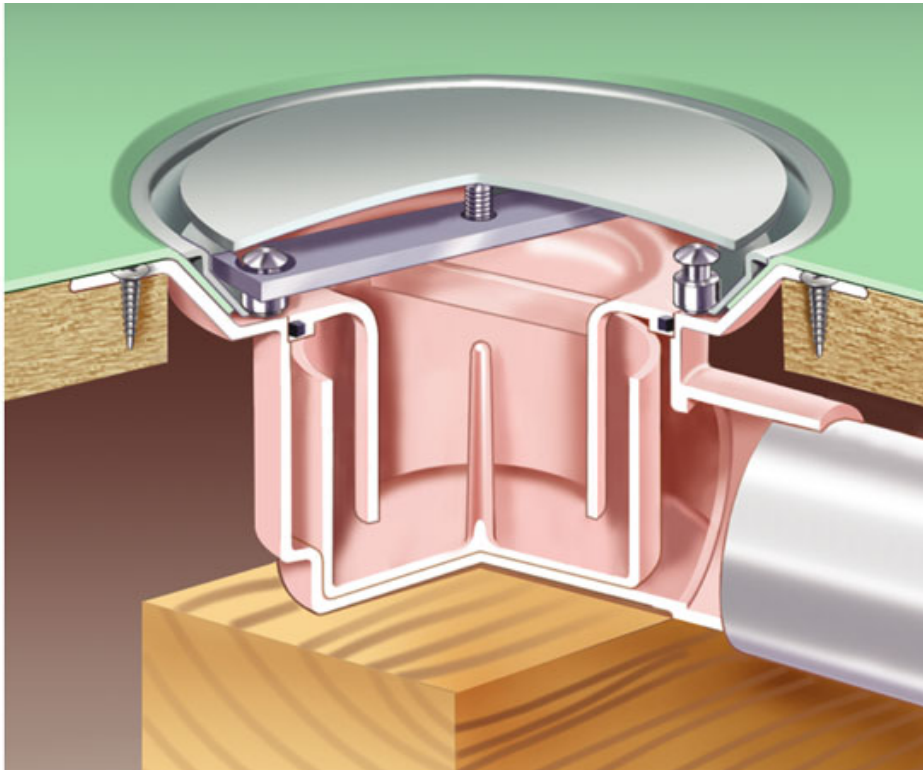

Dimensioned Section for GV5007:

